

- INSTRUCTION MANUAL -

NEW ORDER

TABLE 1A, 2A

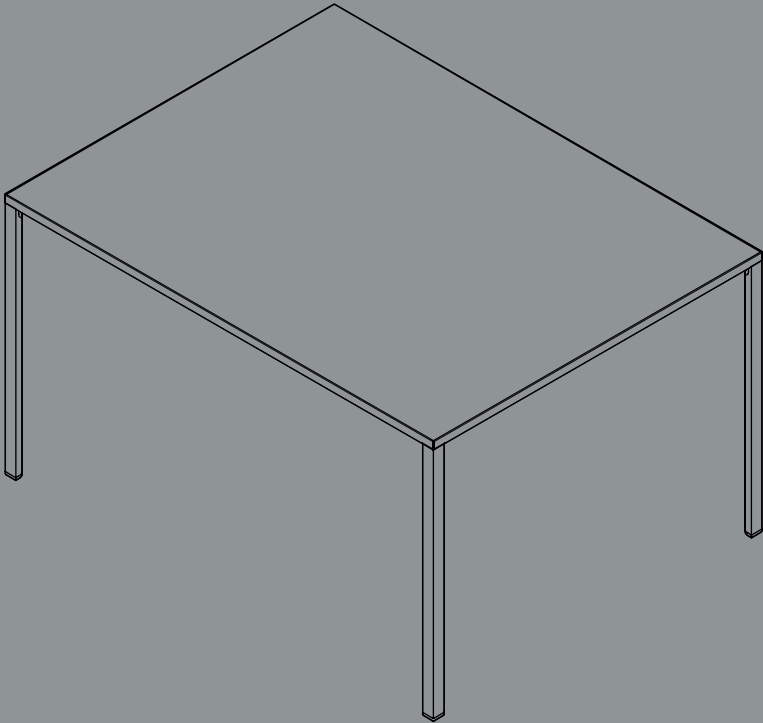

DESIGN BY STEFAN DIEZ

HAY

Developed in collaboration with HAY, Stefan Diez's New Order is a modular shelving and table system designed to fit the ever-changing boundaries of contemporary workspace and living environments. The simple open-grid construction serves as a flexible and functional framework, enabling the user to create customised open or closed storage solutions with optional drawers, doors and panels. New Order's multifunctional tables are suitable as dining tables or meeting tables, used alone in a private setting or integrated with the shelving system and other space management components to make personalised workspace solutions. Diverse colour and material options extend the design possibilities, offering a versatile and aesthetic system.

- TABLE OVERVIEW -

It is important to start by identifying your table model to ensure you follow the correct assembly instructions.

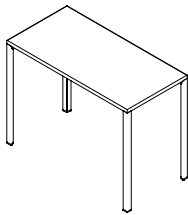

TABLE 1A
100x50

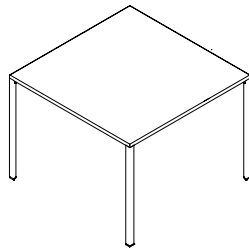



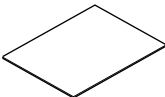





TABLE 2A
100x100

- PARTS -

TABLE		TABLE 1A	TABLE 2A
PART			
	A Corner knot *	x4	x4
	B Frame profile	x4	x4
	C Leg *	x4	x4
	D Tabletop	x1	x1
	4 Frame	x1	x1
	5 Tabletop	x1	x1
	6 Legs	x1	x1

* Quantity of corner knots and legs depends on your table configuration.

1.

Insert the corner knots **A** into the two shortest table frame profiles **B**. Then connect these with the two longest profiles to close the frame.

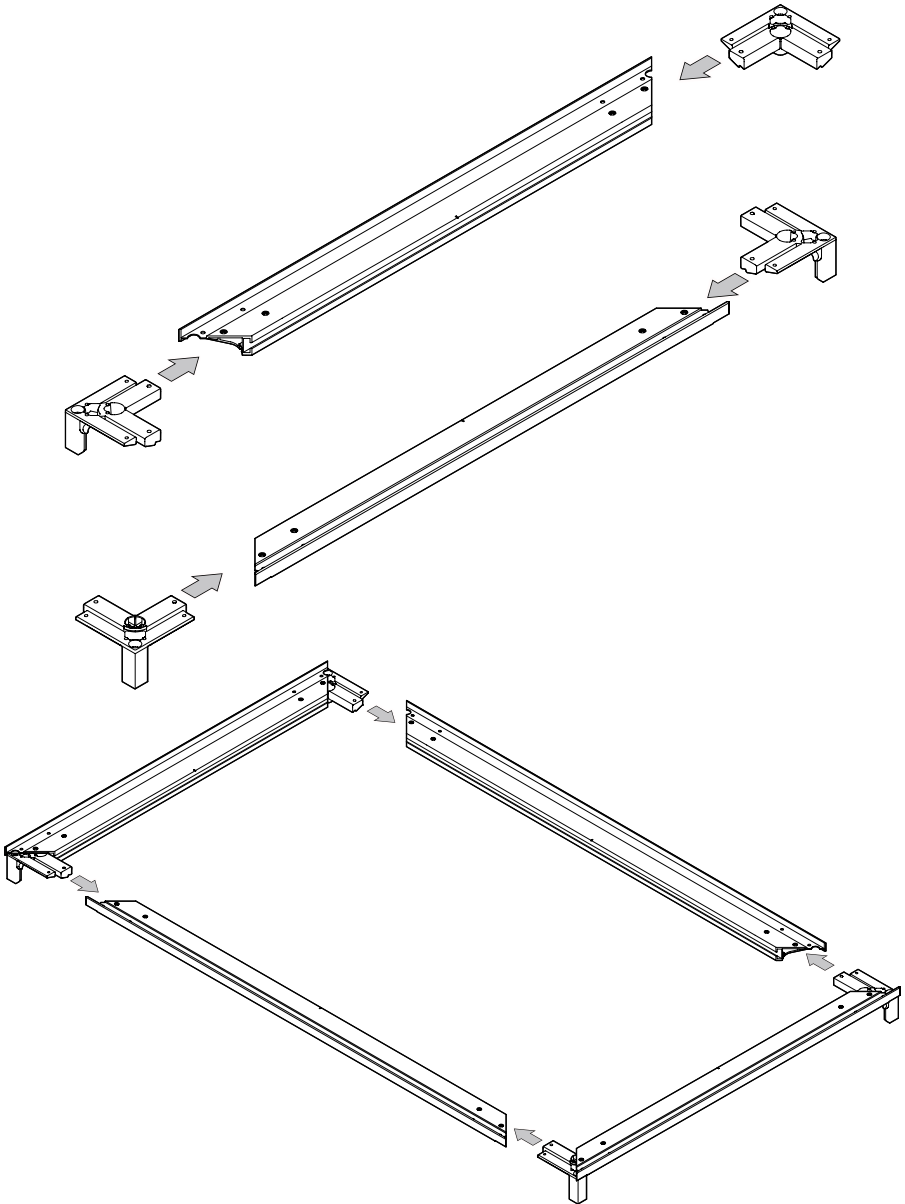

2.

Secure the frame with screws **4B** using tool **4A** in each corner.

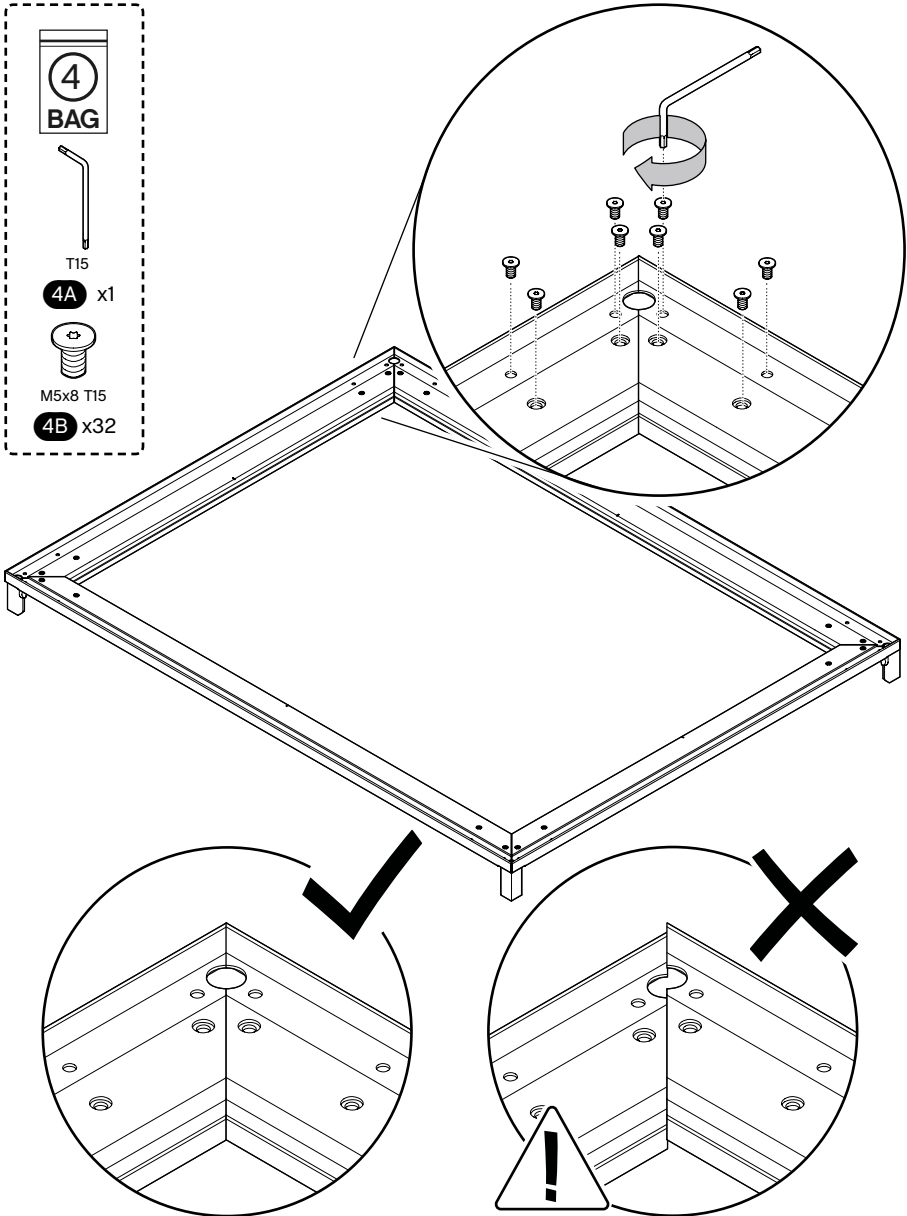

3.

Connect the legs **C** by threading it onto the tap of the corner knot.
Secure with screws **6B** using tool **6A**.

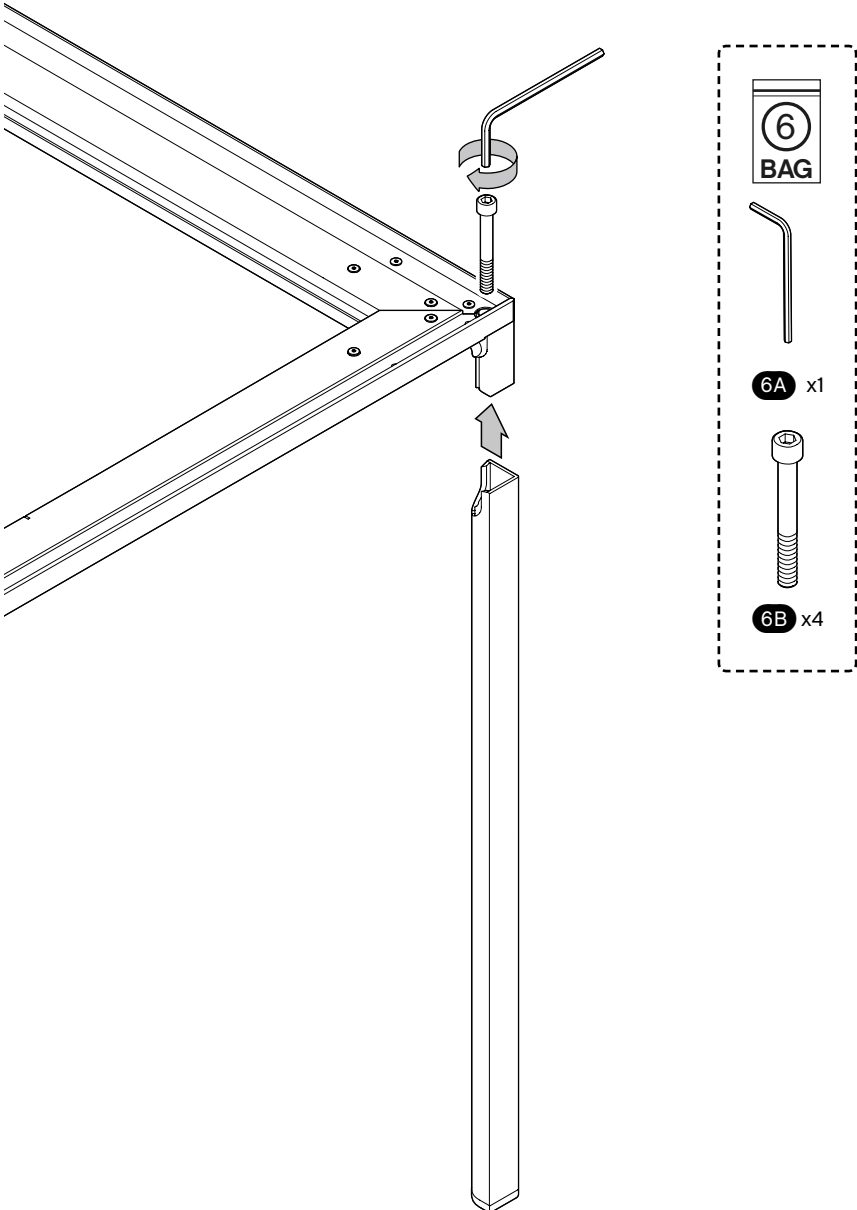

4.

Mount the tabletop **D** by inserting it into one of the short ends. While applying upwards pressure in the middle, push the other short end down into place.

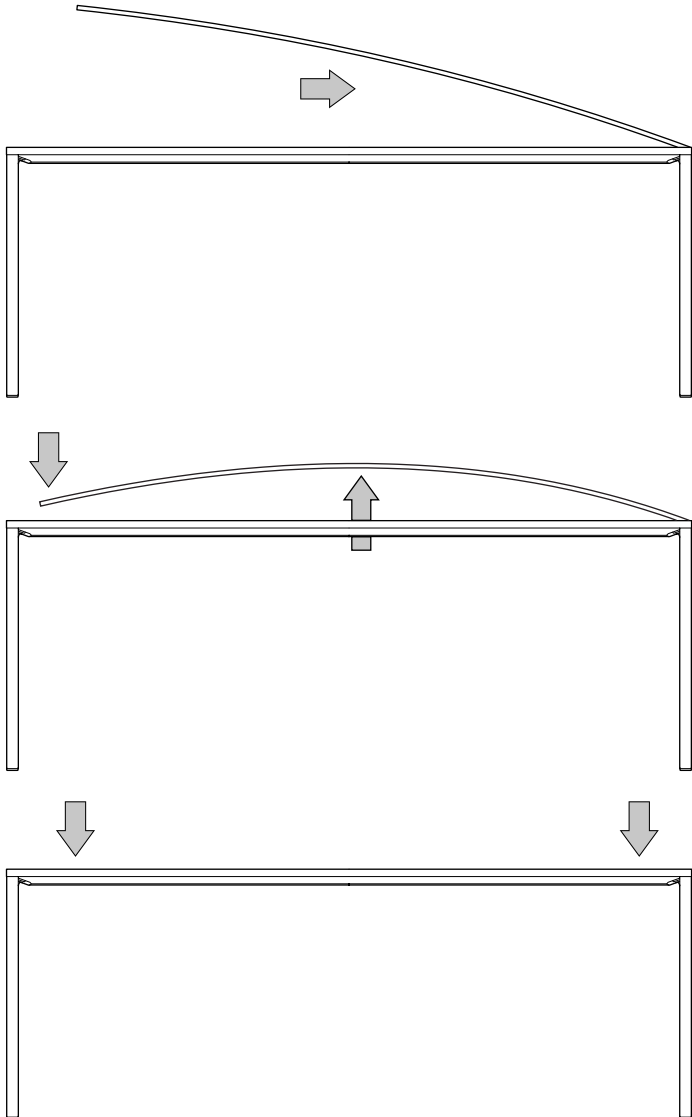

5.

Fasten the tabletop **D** with the clips **5B** from underneath. Distribute the clips evenly.
Secure them with screws **5C** using tool **5A**.

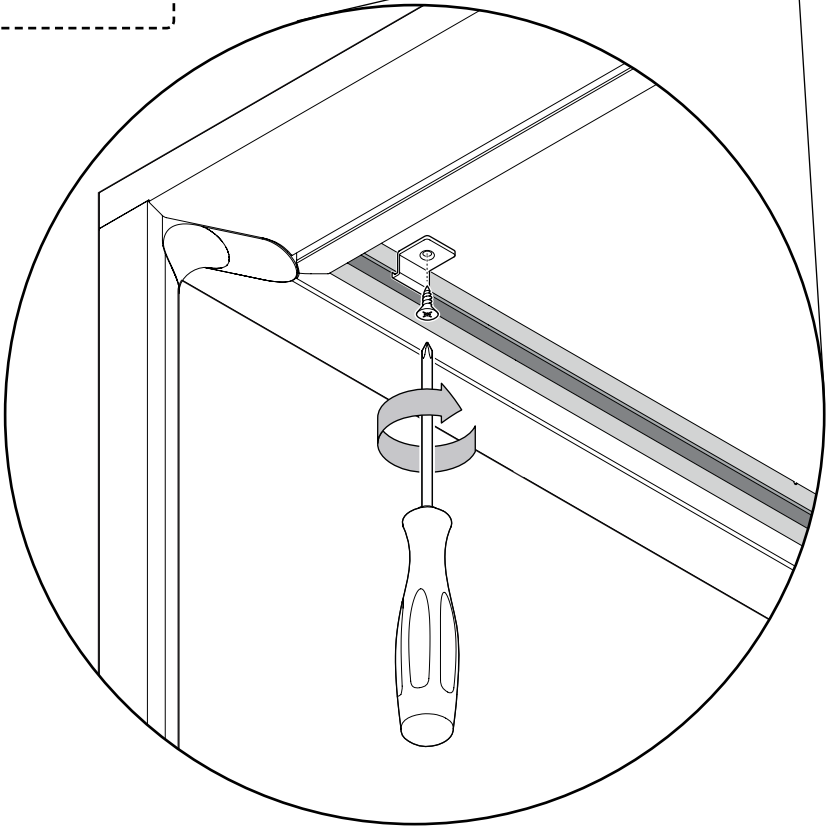
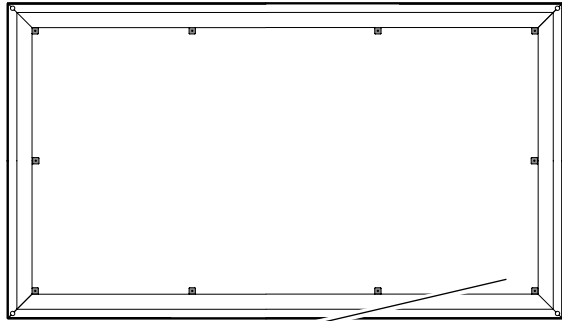
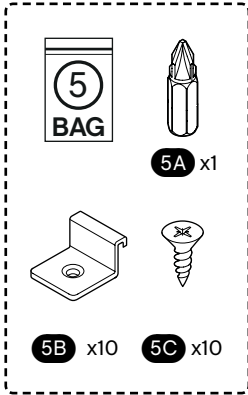

6.

If the floor is uneven and the table is unstable, adjust the height of the feet until the table is stable.

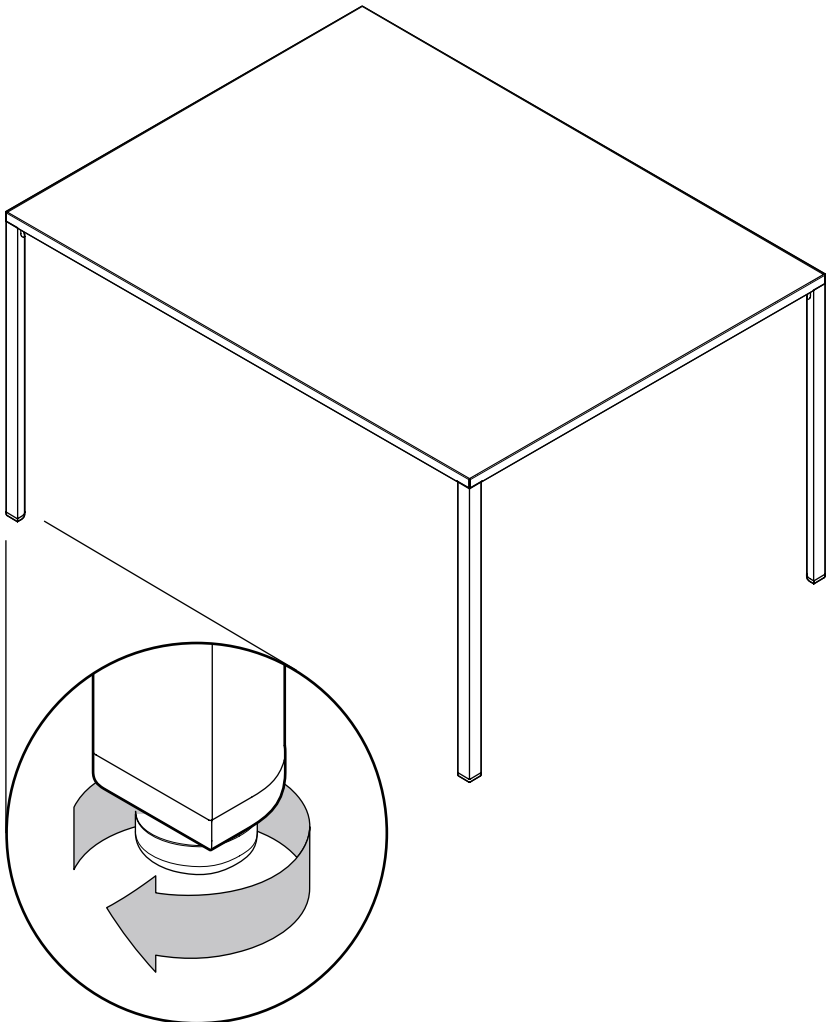

CAUTION

With a little care you can prolong the life of your furniture. Follow the instructions for the materials of your specific product to make sure that it stays in the best shape for as long as possible.

The information below is only intended as a general guideline. For more information on how to remove specific stains, please enquire where you bought the furniture.

- / Always remove stains quickly before they can do any permanent damage to the furniture.
- / Avoid placing the table in direct sunlight or near a heat source to reduce changes. As wood is a natural material, it will change in colour and will patinate over time.
- / When you move your furniture, make sure you lift it rather than pulling or pushing it to avoid damaging the floor, legs and mountings.
- / Tighten up the screws after one to two months' use and whenever required.
- / Avoid improper use such as putting your feet on the table or standing on it.

- / Use coasters under damp, hot or coloured objects to avoid permanent stains.
- / Avoid partially covering the surface, for example with tablecloths, or place mats, as colour variances may appear.
- / Be careful not to scratch or damage the surface with sharp objects.

POWDER COATED ALUMINIUM

- / Clean with a clean cloth wrung in water or in a solution of water and a neutral detergent. Remove soap residue immediately using a clean, dry cloth.
- / Avoid using scouring cream or scouring pads, as they may scratch the surface.

LACQUERED WOOD

- / Wipe with a clean cloth wrung in water or in a solution of water and a neutral detergent. Remove soap residue immediately using a clean, dry cloth.
- / If the surface is scratched or appears matt, use a care product specifically suited to lacquered or stained wood.
- / Avoid using detergents containing silicone, as they seal the stain in and make subsequent repairs more difficult.
- / Avoid using scouring cream or scouring pads, as they may scratch the surface.

LINOLEUM

- / Wipe with a clean cloth wrung in water or in a solution of water and a neutral detergent or soap flakes. Remove soap residue immediately using a clean, dry cloth.
- / If the surface is scratched or appears matt, use a care product especially suited to linoleum.
- / Stains may be carefully removed using white spirit (mineral spirit) or a damp nano sponge dipped in lukewarm water or linoleum care product. Follow up immediately with a clean, dry cloth. Never use the nano sponge dry.
- / Avoid alkaline detergents such as soft (yellow) soap, washing soda, lye and scouring powder.

LAMINATE

- / Wipe with a clean cloth wrung in water or in a solution of water and a neutral detergent. Remove soap residue immediately using a clean, dry cloth.
- / Stains may be carefully removed using household ammonia or with a clean, damp cloth or a nano sponge wrung in warm water. Never use the nano sponge dry. Follow up immediately with a clean, dry cloth.
- / Avoid using scouring cream or scouring pads, as they may scratch the surface.

Havnen 1 8700 Horsens Denmark
+45 4282 0282 / hay@hay.com

02/10/2020

HAY

ITEM NO. 850011



5 7 1 0 4 4 1 2 8 9 8 0 7