

LE KLINT

MUTATIO - LK 353B

Vejledning for

LE KLINT - 353B

Materiale: Lampe i lakeret stål

Lyskilde: 4 W LED-pære

Instructions for

LE KLINT - 353B

Material: Lamp in painted steel

Light source: 4 W LED bulb

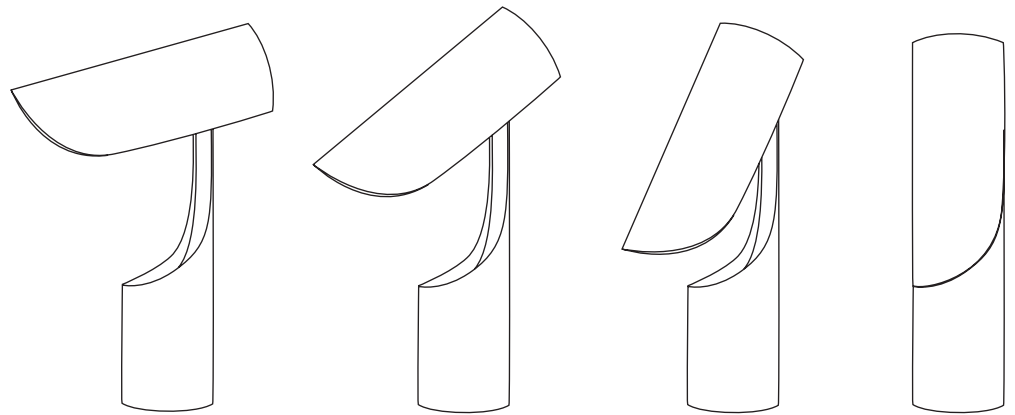

INDHOLD

- Lampe, færdigmonteret
- LED-pære, E14: 4 W
- Instruktion omhandlende udpakning, montage og vedligeholdelse

CONTENTS

- Lamp, ready for use
- LED bulb, E14: 4 W
- Instructions for unpacking, assembly, and maintenance

UDPAKNING & MONTAGE

1. Lampen ligger i mellem de to indlæg, når det øverste indlæg fjernes kommer den til syne.
2. Ved siden af selve lampen ligger lyskilden i egen pakning. Lyskilden pakkes ud og monteres i lampen.
3. Lampen er nu klar til brug.

ASSEMBLY

1. The lamp is located in between the two cardboard supports, when the top support is removed, you can see the lamp.
2. Beside the lamp itself is the light source in its own packaging. The light source is unwrapped and installed in the lamp.
3. The lamp is now ready for use.

TRINLØS ÅBNING AF LAMPE

Denne lampe er udviklet med et specielt led som giver mulighed for at hovedet på lampen kan justeres trinløst, alt efter hvor lyset ønskes hen.

TILTING FEATURE

This lamp is designed with a special detail which allows the head of the lamp to be continuously adjustable, depending on how you want the light.

Lampen slukker ikke automatisk når den lukkes i, derfor er det vigtigt at slukke lampen korrekt på afbryderen og ikke blot lukke den i.

The lamp does not turn off automatically when closed, so it is important to turn off the lamp correctly on the switch.

LYS

Lampen leveres med en LED pære med E14 fatning, da dette giver mulighed for mest muligt lys, uden at der bliver for varmt i selve lampen.

LIGHT

The lamp comes with an LED bulb with E14 socket, as this allows the most light without being too hot in the lamp itself.

I fald lampen lukkes helt sammen er det vigtigt at slukke lampen, ellers kan lyskilden blive overophedet og dermed tage skade.

In case the lamp is completely closed together, it is important to turn off the lamp, otherwise the light source may overheat and thus be damaged.

Det anbefales at benytte den medfølgende LED pære eller en sparepære, med lille rundt hoved (kronepære) for at pæren skjules bedst muligt i lampen.

It is recommended to use the supplied LED bulb or an energy saving lamp, with a small round head in order for the light source to be concealed inside the lamp.

BORTSKAFFELSE AF LYSKILDE

Denne lampe leveres inkl. lyskilde. Følg anbefalinger for miljørigtig håndtering og bortskaffelse.

DISPOSAL OF LIGHT SOURCE

Please adhere to the recommended state environment regulations when disposing of any electrical components.

VEDLIGEHOLD

Skærmen holdes ren ved aftørring med blød klud eller støvbørste.

MAINTENANCE

The lamp is kept clean by wiping with a soft cloth and dust brush.

Vær opmærksom på at lakken udvendigt på lampen, samt den hvide højglans indvendigt kan tage skade ved brug af rengøringsmidler og sprit.

Be aware that the paint on the outside of the lamp and the white gloss interior can be damaged by the use of detergents and alcohol.



The table lamp MUTATIO, with its iconic design inspired by transformation and minimalist geometry. The model is now available as a table lamp and launched in a short time also as a wall edition. The lamp's clean lines and clear function fits well with the classic table and floor lamps that have been the characteristic of Le Klint since the company was founded in the 1940s.

With this lamp has in particular the interplay between closed and open part of the designer's idea, this transformation in shape is further emphasized by the matt black exterior and white gloss lacquered inside. The lamp will do well on the desktop, rack or other places where space is limited, but the desire for light and good design is top notch.

Bordlampen MUTATIO er med sit ikoniske design inspireret af transformation og minimalistisk geometri. Lampens rene linjer og klare funktion harmonerer flot med de klassiske bord- og gulvlamper som har været kendetegnende for LE KLINT siden firmaets start i 1940'erne.

Med denne lampe har især samspillet mellem lukket og åben været en del af designerens ide, denne transformation i formen understreges ydermere af den matte sorte yderside og den hvide højglans lakerede inderside. Lampen vil gøre sig godt på skrivebordet, reolen eller andre steder hvor pladsen er trang, men ønsket om lys og godt design er i top.



Christian Troels

MUTATIO LK 353B - Ø 8 cm, H 30 cm

Designet af: Christian Troels
Designår: 2013
Producers af: LE KLINT A/S

MUTATIO LK 353B - Diam. 8 cm, H 30 cm

Designed by: Christian Troels
Year of design: 2013
Production by: LE KLINT A/S

